

# RSB150 NX RSB150H NX (HEPA)

NUMATIC RUCKSACK VACUUM  
BATTERY POWERED  
AUSTRALIAN

# Numatic

numatic.com

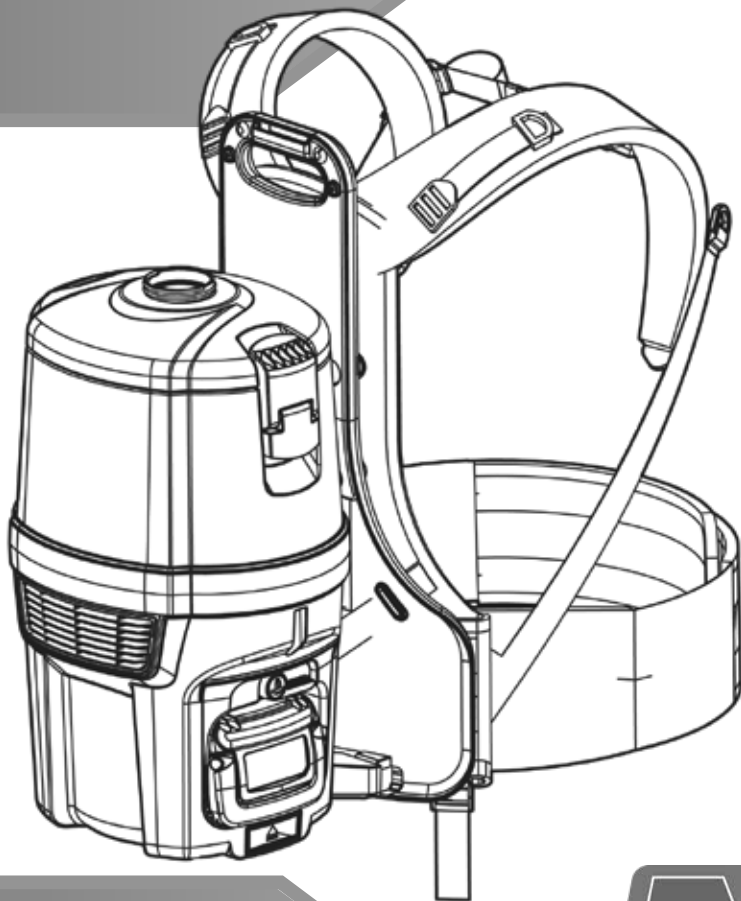

## Original Instructions

CAUTION,  
Read the Instructions before using the machine.



Edgar Edmondson Pty Ltd

Head Office  
PO Box 198  
Marrickville  
NSW 1475  
AUSTRALIA

Delivery and Shipping Address  
18 Garden St  
Marrickville  
NSW 2204  
AUSTRALIA

Office Number: 1800 BUY MOP  
Fax Number: +61 (0)2 9519 9223  
E-Mail: [orders@edmondson.net.au](mailto:orders@edmondson.net.au)  
ABN: 27 000 450 144

# Edco

## Kit AA30E with 902072 (PF270)

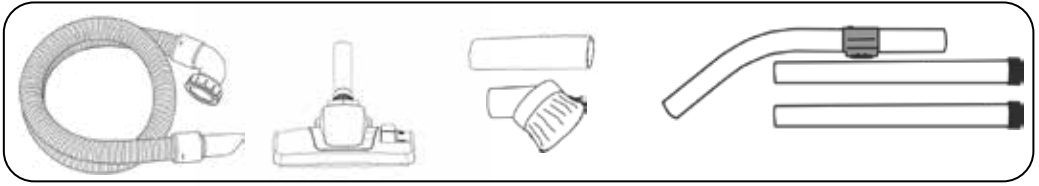

## Kit AAT30E with 902072 (PF270)

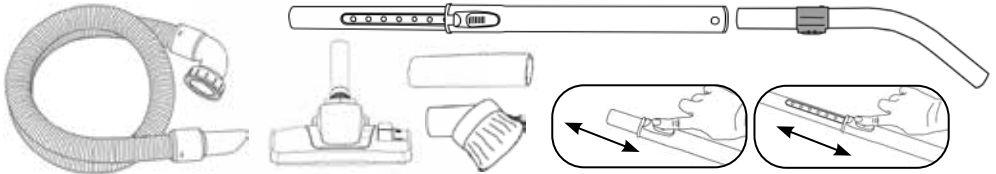

## Assembly

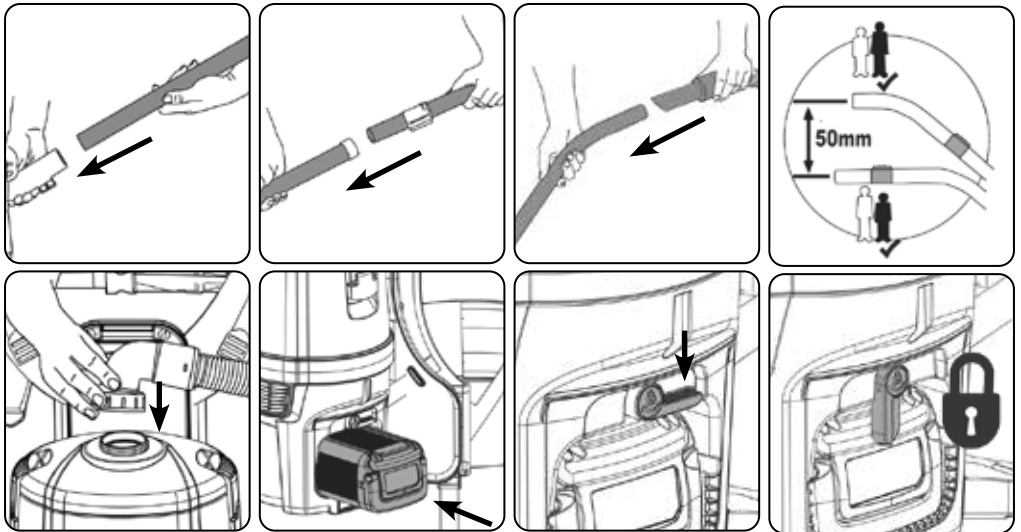

## Floortool adjustment

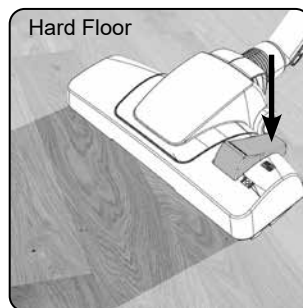
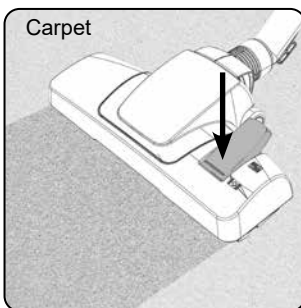

# Using the machine

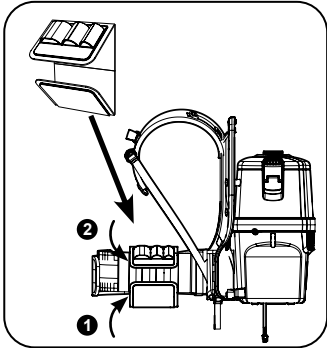

Ensure harness is straight and level.

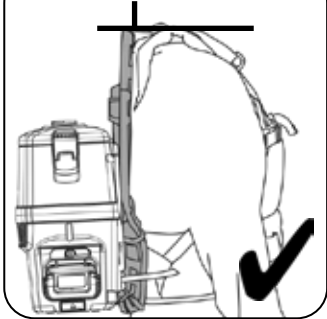

Adjust to fit.

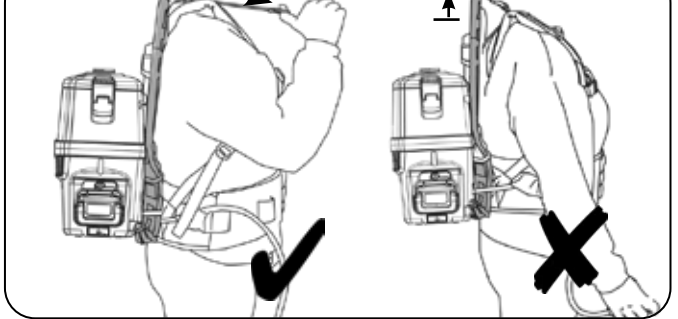

Adjusting harness height

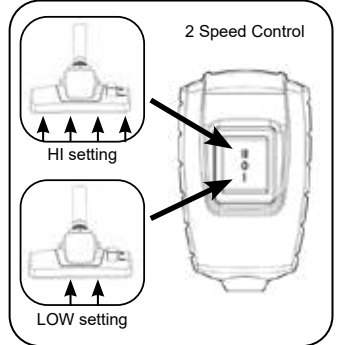
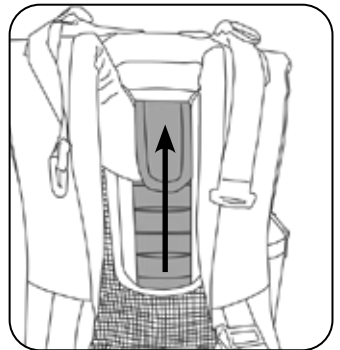
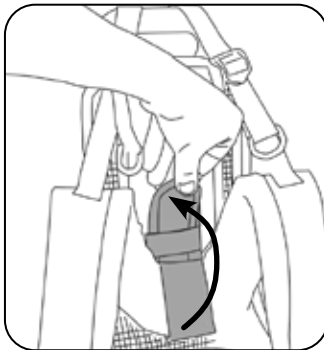
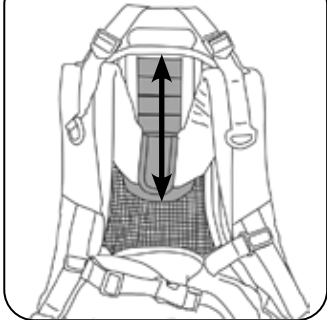

# Cleaning your machine

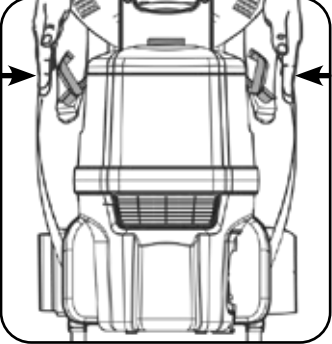
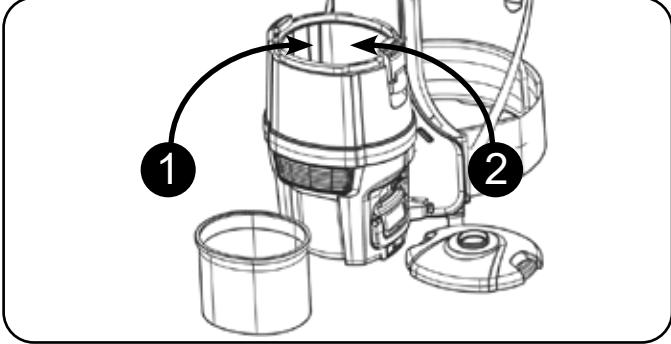
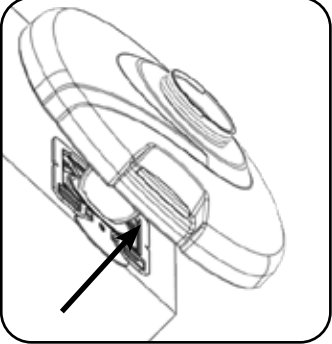
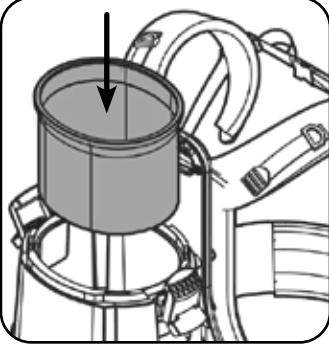
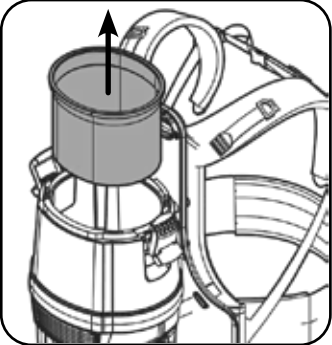
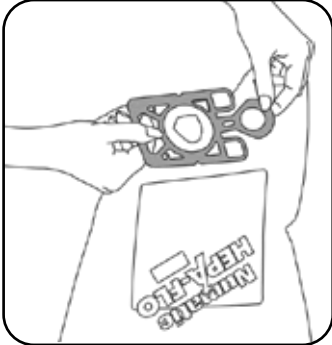
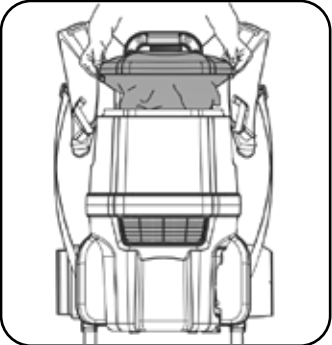
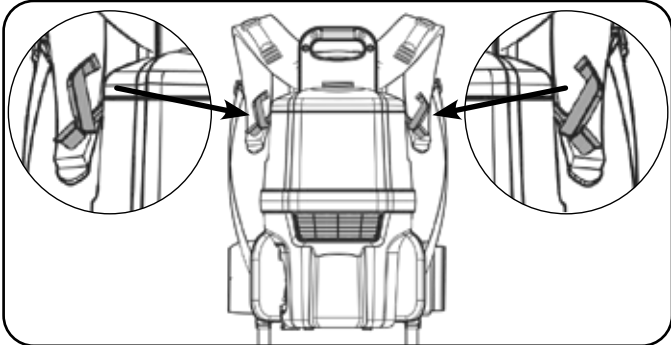

# Replacing the Cartridge Filter

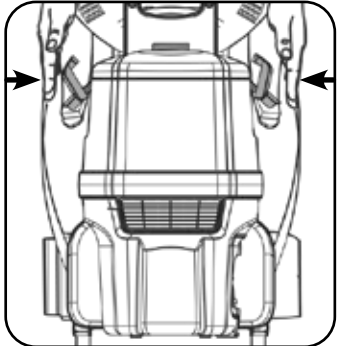
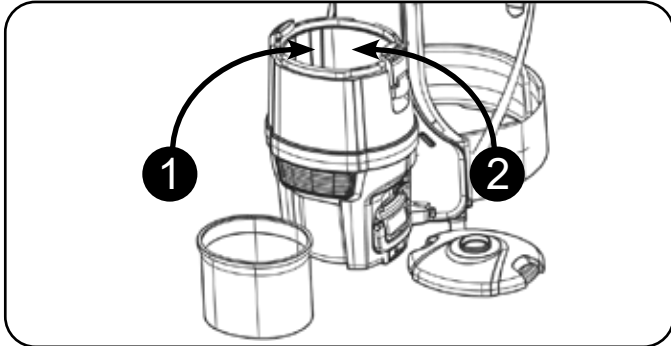
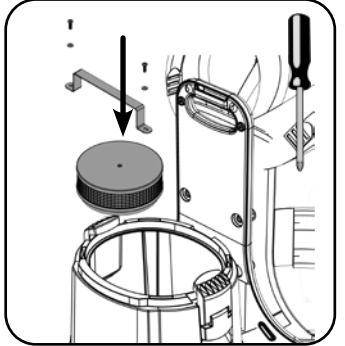
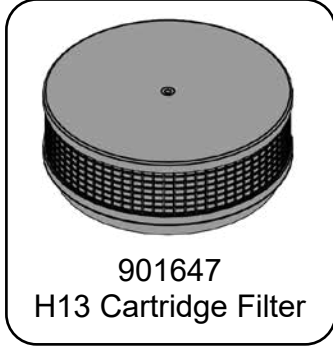
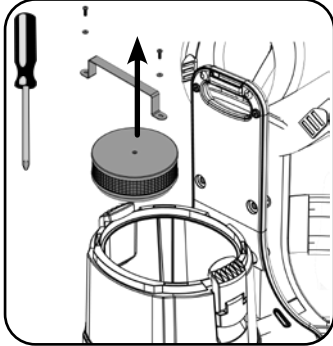
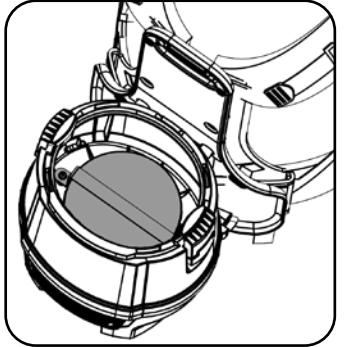
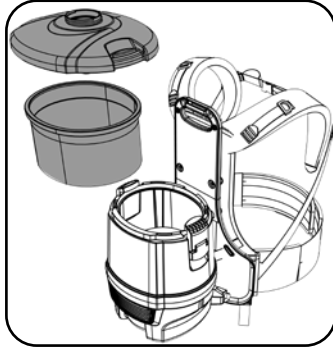
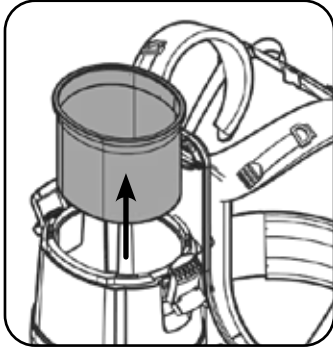
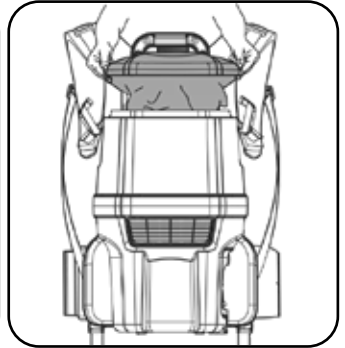
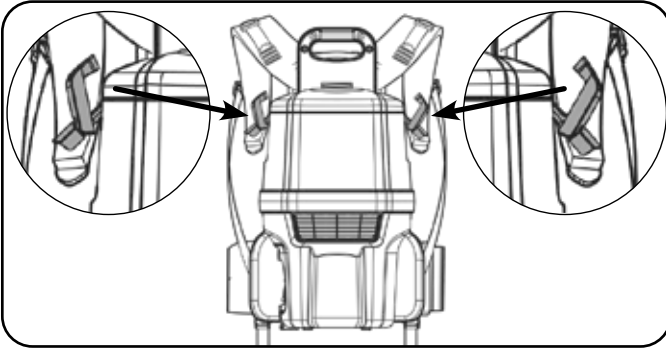

# Charging your battery

For information relating to the operation and charging of your battery please refer to the battery and charger original operating instructions

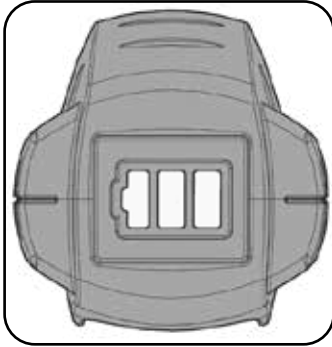

Cleaning time

HI = 49 mins

LO = 83 mins

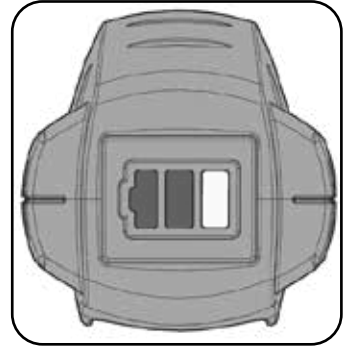

## Data

	Voltage	Power Input	Airflow	*Run time	Size
RSB	36V (DC)	350 W / 200 W	HI = 24.0 L/sec LO = 19.9 L/sec	*HI = 49 Mins *LO = 83 Mins	570 mm x 330 mm x 330 mm
RSB (HEPA)			HI = 22.7 L/sec LO = 18.0 L/sec		
	Weight	Dust bag	Capacity	*Charge time	
RSB	8.2 kg	NVM-1AH	3.0 Ltr	*1hr to 80% charge – fast charger *2hrs to 100% charge – fast charger	
RSB (HEPA)	8.6 kg		2.0 Ltr		
	High Power Mode			Low Power Mode	
RSB	Sound Pressure (LpA): 63.0dB(A) Uncertainty (KpA): 0.5dB			Sound Pressure (LpA): 62.0dB(A) Uncertainty (KpA): 0.5dB	
RSB (HEPA)	Sound Pressure (LpA): 66.5dB(A) Uncertainty (KpA): 0.5dB			Sound Pressure (LpA): 64.0dB(A) Uncertainty (KpA): 0.5dB	
*Run and Recharge times may vary dependent on ambient temperature.					

1	Voltage / Direct Current
2	Rated input power
3	Weight (ready to work)
4	Company name & address
5	Model
6	Machine yr/wk Serial number
7	Approval Mark
8	Use Lithium-Ion Battery Only

Rating Label

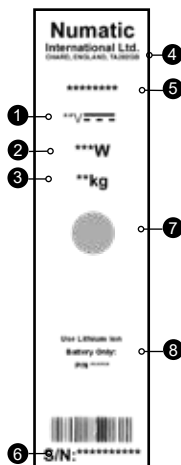

PPE (personal protective equipment) That may be required for certain operations.

Ear Protection	Safety Footwear	Head Protection	Safety Gloves	
Eye Protection	Protective Clothing	Dust / Allergens Protection	Hi Viz Jacket	Caution Floor Sign
<p>Note: A risk assessment should be conducted to determine which PPE should be worn.</p>				

Failure to rectify the problem or in the event of a breakdown contact your Numatic dealer or the Numatic Technical helpline +44 (0)1460 269268

**Daily**

- Keep the machine clean, including hoses and tubes.
- Ensure the bag and filter are fitted.
- Regularly examine the charger.
- Check dust bag frequently.
- Check filters are clean.

**Weekly - as daily and:-**

- Check for any worn or damaged parts and replace immediately.
- Do not steam clean or pressure wash.

**Batteries**

Always recharge the batteries after use.

Safety Critical Components

Multi-Regional Charger (100-240V ~ 50/60 Hz)

Lithium- Ion Battery 8.1 Ah



# Information for Dry use Battery Vacuum cleaners

Original Instructions. Read Manual before use.



## Warning

Read the instruction manual before using the machine.

Operators shall be adequately instructed on the use of these machines, as with all electrical equipment, care and attention must be exercised at all times during use, you must also make certain that routine and preventative maintenance is carried out periodically to ensure safe operation.

Failure to carry out maintenance as necessary, including the replacement of parts to the correct standard could render this equipment unsafe and the manufacturer can accept no responsibility in this respect.

This machine is for DRY USE only.

You must remove the battery from the machine BEFORE cleaning or maintenance and when replacing parts or converting the machine to another function.

This appliance is intended to be assembled, cleaned and maintained by an adult.

This machine is not suitable for the collection of biological hazards, hazardous or explosive dusts.

Contact your local distributor if you require a machine capable of performing these tasks.

This machine is not intended for use by persons (including children) with reduced physical, sensory or mental capabilities, or lack of experience and knowledge.

Children should be supervised to ensure that they do not play with the appliance.

This machine is not a toy; children shall not play with this machine.

## Caution

This machine must not be stored outside, or used in wet environments, or to collect wet materials.

The vacuum cleaner should be stored in a dry place and is for indoor use only.

You must ensure that the filtration system fitted to the machine is suitable for the material being collected.

## Note:

The primary use for this machine is commercial, for example in hotels, schools, hospitals, factories, shops and offices.

This product complies with the requirements of clause 20 of EN/IEC 60335-2-69 Stability and Mechanical Hazards.

This vacuum cleaner is fitted with a thermal protection device.

If the vacuum cleaner has a blockage, remove the battery and inspect the floor tool, tubes and hose for debris.

If the floor tool, tubes and hose are clear, replace the dust bag and clean the filter.

The vacuum cleaner should be inspected after use for damage.

The vacuum cleaner should be stored in a dry place.

## Do

- Keep your machine clean including hoses and tubes.
- Change dust bag frequently.
- Keep filters clean.
- Keep diffuser filter (where fitted) clean.
- Use filter bags, they will enhance performance and help keep machine clean.
- Use a Numatic Original filter bag under fine dust conditions.
- Keep hoses and tubes clear.
- Replace any worn or damaged parts immediately.

## Don't

- Use to suck up hot ashes or lighted cigarette ends.
- Use steam cleaners or pressure washers to clean the machine or use in the rain.
- Immerse in water for cleaning.
- Attempt machine maintenance or cleaning unless battery has been removed from the machine.
- Do not use in wet environments or to collect wet materials.

Under any circumstances place foreign objects including (but not limited to) air fresheners, air freshener capsules or scented beads of any type into the top filter of the machine. Doing so can be dangerous and risk damage to the machine and may invalidate the machine warranty.

# Replacement parts

Filter	
910915 / 910945	Tritex filter
901647	H13 Cartridge Filter
HepaFlo dust bags	
604011	NVM-1AH Dust bags (Pack of 10)
Battery	
909996	37 V Battery
Charger	
911334	Charger Dock Australian
912360	Charger Cable Australian

# Schematic diagram

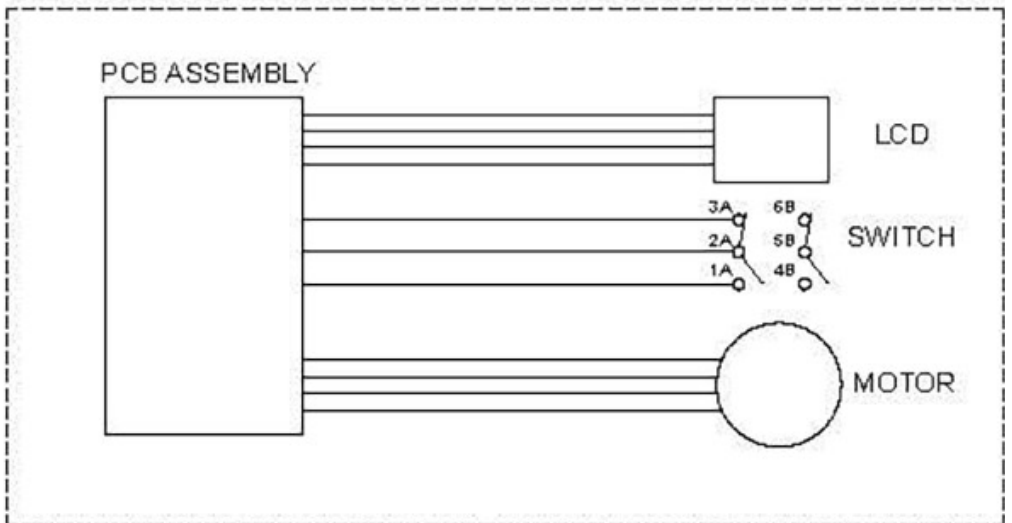





# Warranty

**Numatic International Limited warrant to the original purchaser that its products are free of defects in both material and workmanship for the period shown below:-**

**Homecare and Procure Vacuum cleaners..... 2 Years**  
**Rotary Floor Machines..... 1 Year**  
**Twintec Auto Scrubber Dryer..... 1 Year**  
**Vario Ride-On Scrubber Dryer..... 1 Year / 1500 hours**  
**Mopping, Compacts, Versaclean and Versacare Products..... 1 Year**  
**Individual Accessories and Spare Parts..... 6 Months**

Note: This warranty expressly excludes consumable parts such as carbon brushes, floor brushes, mops, batteries etc, that are considered replaceable from time to time during the normal working life of the machine.

Our goods come with guarantees that cannot be excluded under the Australian Consumer Law. You are entitled to a replacement or refund for a major failure and for compensation for any other reasonably foreseeable loss or damage. You are also entitled to have the goods repaired or replaced if the goods fail to be of acceptable quality and the failure does not amount to a major failure.

The benefits under (Our Warranty) are in addition to other rights and remedies under a law in relation to the (goods/services)

- A. The warranty period commences from the date the goods are purchased. We advise all purchasers to retain their invoice as proof of purchase.
- B. All warranty claims must be processed through either the Dealer from whom the equipment was originally purchased or another authorised Edgar Edmondson Pty Ltd Australia dealer. The Dealer will co-operate with the purchaser throughout the warranty claims procedure and will arrange any necessary repairs using genuine Numatic parts.
- C. If the original Dealer is no longer able to fulfil his obligations please contact Edgar Edmondson Pty Ltd Australia with full details of the claim and proof of purchase so that this may be processed without delay.
- D. Any warranty claim can only relate to the specific part that is proven to be at fault and for which a replacement will be supplied but cannot be extended to constitute a claim against the complete machine.
- E. Edgar Edmondson Pty Ltd Australia will supply the Dealer with any warranty parts required, subject to the claim being validated.
- F. Claims will not be accepted if they are the result of fair wear and tear, misuse or abuse of any kind.
- G. No replacement will be given unless the appropriate evidence of the validity of the claim has been provided to the satisfaction of Edgar Edmondson Pty Ltd Australia.
- H. Edgar Edmondson Pty Ltd Australia reserve the right to charge for any work carried out as a result of an invalid claim.
- I. No variation to this warranty may be made or implied by any member of Edgar Edmondson Pty Ltd Australia or its Dealers unless such variation is in writing and authorised by the Company.

Australian Importer.

Edgar Edmondson Pty Ltd

Head Office	Delivery and Shipping Address	Office Number: 1800 BUY MOP
PO Box 198	18 Garden St	Fax Number: +61 (0)2 9519 9223
Marrickville	Marrickville	E-Mail: <a href="mailto:orders@edmondson.net.au">orders@edmondson.net.au</a>
NSW 1475	NSW 2204	
AUSTRALIA	AUSTRALIA	ABN: 27 000 450 144

# Edco

244030 10/21 (A03)

# Numatic

Distributed by:-

Edgar Edmondson Pty Ltd

Head Office	Delivery and Shipping Address	Office Number: 1800 BUY MOP
PO Box 198	18 Garden St	Fax Number: +61 (0)2 9519 9223
Marrickville	Marrickville	E-Mail: <a href="mailto:orders@edmondson.net.au">orders@edmondson.net.au</a>
NSW 1475	NSW 2204	
AUSTRALIA	AUSTRALIA	ABN: 27 000 450 144

# Edco

Numatic International Limited.  
Chard, Somerset TA20 2GB ENGLAND  
Tel: 01460 68600 [www.numatic.co.uk](http://www.numatic.co.uk)

UNITED KINGDOM: [www.numatic.com](http://www.numatic.com) GERMANY: [www.numatic.de](http://www.numatic.de) SWITZERLAND: [www.numatic.ch](http://www.numatic.ch)  
FRANCE: [www.numatic.fr](http://www.numatic.fr) NETHERLANDS: [www.numatic.nl](http://www.numatic.nl) SOUTH AFRICA: [www.numatic.co.za](http://www.numatic.co.za)  
PORTUGAL: [www.numatic.pt](http://www.numatic.pt) SPAIN: [www.numatic.es](http://www.numatic.es) DENMARK: [www.numatic-online.dk](http://www.numatic-online.dk)

Specification subject to change without prior notice  
[www.numatic.com](http://www.numatic.com) © Numatic International Limited